

- up to 8 GPON line ports
- Ideal solution for a cottage village or an apartment building
- Remote control via CLI, SNMP
- G.988, G.984.x and TR-156 Standard
- Ability to provide cable TV together with data communication services



LTP-4X



LTP-8X

Optical Line Terminal (OLT) is designed to provide broadband access over Passive Optical Network (PON).

GPON interfaces are used to connect the optical distribution network (PON). You can connect up to 64 subscriber optical terminals via a single fibre for each interface. Access to the operator's transport network is provided through 10 Gigabit or combined Gigabit uplink interfaces.

OLT LTP-8X allows the operator to build scalable, fault-tolerant "last mile" networks to ensure the highest safety standards. OLT manages subscriber devices, traffic switching and connection to the transport network.

Broadband access using FTTH technology is the highest quality version of the Triple Play service delivery, as it provides high data rates over long distances. The main advantage of PON technology is the lack of electrically powered active nodes within the section from OLT to ONT, which greatly reduces the network operating cost. What's more, PON technology saves on cabling infrastructure by reducing the total length of the optical fibre, as only one fibre for a group of up to 64 subscribers is used within the section from the central node to the splitter.

SPECIFICATIONS

Name	PON line ports	Uplink ports	ONT support
OLT LTP-4X	4	4 x combo 10/100/1000Base-T/ 1000Base-X 2 x 10GBase-X (SFP+)	512
OLT LTP-8X	8	4 x 10/100/1000Base-T ports 4 x combo 10/100/1000Base-T/ 1000Base-X ports 2 x 10GBase-X (SFP+) ports	1024

TECHNICAL SPECIFICATIONS

INTERFACES

LTP-4X

Uplink

- 2 x 10GBase (SFP+)/1000 Base-X ports
- 4 x Combo 10/100/1000 Base-T/1000 Base-X (SFP)

Subscriber Line Interfaces

- 4 x GPON (2.5/1.25 Gbps)

LTP-8X

Uplink

- 2 x 10GBase (SFP+)/1000 Base-X
- 4 x Combo 10/100/1000 Base-T/1000 Base-X (SFP)

- 4 x 10/100/1000 Base-T

Subscriber Line Interfaces

- 8 x GPON (2.5/1.25 Gbps)

GPON

- 9/125, G.652 μm single-mode fiber (SMF)
- Up to 1:64 splitting ratio
- Received Signal Strength Indication (RSSI)
- Support DDM (show parameters in CLI)
 - Digital RSSI
 - Module Temperature
 - Supply Voltage
 - Laser Bias Current
 - Tx Optical Power Output

Class B+:

- Standard ITU-T G.984.2, FSAN Class B+, SFF-8472
- Max link distance – 20 km
- Transmitter: 1490nm DFB Laser
 - Data Rate: 2488Mbps
 - Average Launch Power +1,5..+5 dBm
 - Spectral Line Width-20 dB 1.0 nm
- Receiver: 1310nm APD/TIA Detector/Amplifier
 - Data Rate: 1244Mbps
 - Receiver Sensitivity -28 dBm
 - Receiver Optical Overload -8 dBm

Class C+:

- Standard ITU-T G.984.2, FSAN Class C+, SFF-8472
- Max link distance – 60 km
- Transmitter: 1490nm DFB Laser
 - Data Rate: 2488Mbps
 - Average Launch Power +3..+7 dBm
 - Spectral Line Width-20 dB 1.0 nm
- Receiver: 1310nm APD/TIA Detector/Amplifier
 - Data Rate: 1244Mbps
 - Receiver Sensitivity -32 dBm
 - Receiver Optical Overload -2 dBm
- Receiver Burst Mode Dynamic Range 20 dB

SWITCHING

- Ethernet switcher - Marvell Packet Processor
- 128 Gbps switch capacity
- MAC addresses - 16K
- 4K active VLAN, IEEE802.1Q, double tagging (Q-in-Q)
- QoS

SWITCHING

- Processor - Marvell Packet Processor
- 128 Gbps switch capacity
- MAC addresses - 16K
- 4K active VLAN, IEEE802.1Q, double tagging (Q-in-Q)
- QoS

PHYSICAL AND ENVIRONMENTAL SPECIFICATIONS

- Power:¹
 - 220 V (150-250 V) AC, 50 Hz
 - 48 V (-36..-72) DC
- Max Power: 20W
- Ambient Operating Temperature: +5 to 40 C °
- Humidity: up to 80%, non-condensing
- Dimensions: with internal power supply module 430x44x258 (HxWxD) mm, 19", 1U

STANDARD COMPLIANCE

- ITU-T G.988 GPON
- ITU-T G.984x GPON
- IEEE 802.3i 10BASE-T Ethernet
- IEEE 802.3u 100BASE-T Fast Ethernet
- IEEE 802.3ab 1000BASE-T Gigabit Ethernet
- IEEE 802.3z Fiber Gigabit Ethernet
- ANSI/IEEE 802.3 NWay auto-negotiation
- IEEE 802.3x Full Duplex and flow control
- IEEE 802.3ad Link aggregation
- IEEE 802.1p Protocol for Traffic Prioritization
- IEEE 802.1Q Virtual LANs
- IEEE 802.1ad Provider Bridges (QinQ)
- IEEE 802.1v VLAN Classification by Protocol and Port
- IEEE 802.3ac VLAN tagging
- IEEE 802.1d MAC bridges
- IEEE 802.1w Rapid Reconfiguration of Spanning Tree
- IEEE 802.1s Multiple Spanning Trees

FEATURES AND BENEFITS

- MAC-address learning/aging
- MAC-address-table limit
- Handling unknown MAC-address
- Handling multi-addresses traffic
- Support to 1024 multicast groups
- Double tagging (Q-in-Q), IEEE 802.1ad
- IGMP Proxy
- IGMP Snooping
- IGMP fast leave
- VLAN 1 port-isolation
- STP, RSTP, MSTP

MANAGEMENT

- CLI, SNMP
- Eltex.EMS (Eltex Management System)

¹You can choose this option when ordering

CENTRALIZED MANAGEMENT SYSTEM

Eltex.EMS is a centralized network device management system made by Eltex.

MAIN FUNCTIONS

- search, adding, setting, monitoring of OLT/ONT devices and other network devices
- device parameters and power supply monitoring
- monitoring of physical and logical interface statistics
- management of customer profiles
- administration of mass firmware update system for customer PON devices
- displaying dynamic graphs of various statistics parameters online
- displaying graphic presentation of physical port status
- quick start system for main configuration tools: SSH, Telnet, Web



STATISTICS

- centralized gathering, storage, precessing of working journals, actioons, crashes
- gathering and storage of log messages
- quick CPE search in optical trees
- information on the large number of active subscribers on the PON network
- Internet, VoIP and IPTV services monitoring and customer statistic collection
- logging of all users' actions in the system

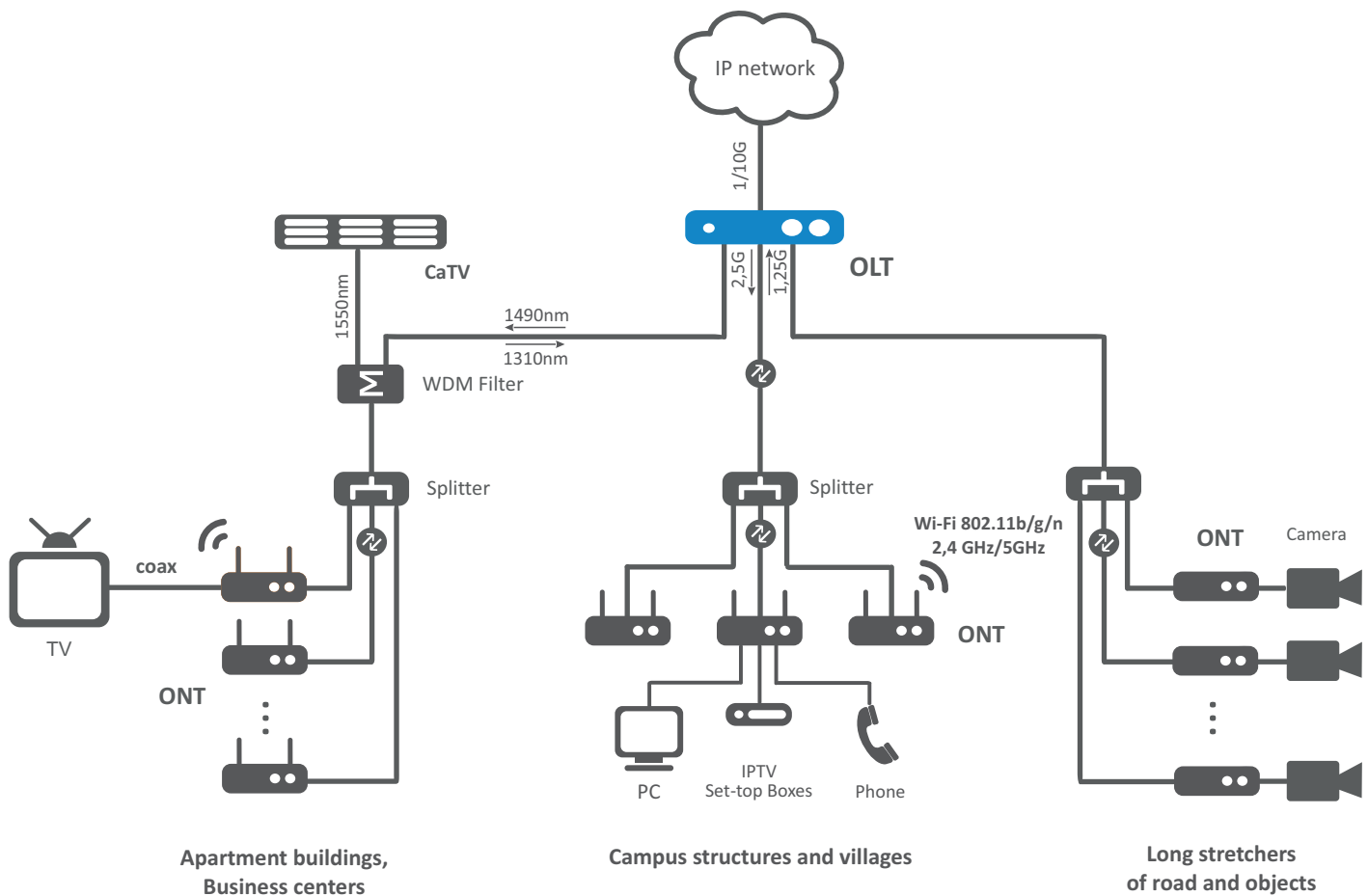

SCHEME OF USING



ORDERING INFORMATION

Name	Description	Picture
OLT LTP-4X	OLT LTP-4X, 4 PON ports (SFP), 4 combo 10/100/1000Base-T/1000Base-X ports, 2 x 10GBase-X (SFP+) ports, L2+, RSSI	
OLT LTP-4X	OLT LTP-4X, 8 PON ports (SFP), 4 x 10/100/1000Base-T ports, 4 combo 10/100/1000Base-T/1000Base-X ports, 2 x 10GBase-X (SFP+) ports, L2+, RSSI	

Additional Modules

PM160-220/12	Power supply module PM160-220/12, 220V AC, 160W	
PM75-48/12	Power supply module PM75-48/12, 48V DC, 75W	

Software

EMS-OLT	Eltex.EMS management system option EMS-OLT for management of network equipment Eltex per 1 OLT
---------	--

About Eltex

For more than twenty years major Russian company Eltex Enterprise, Ltd been designing and manufacturing a wide range of telecommunications and networking equipment: GPON devices, Ethernet-switches, Service Routers, Wireless, VoIP-gateways, Softswitch & IMS, Set-top Boxes and much more.

Contact Us



+7 (383) 274 10 01
+7 (383) 274 48 49



eltex@eltex.nsk.ru



www.eltex.nsk.ru

