

- High performance
- Support for stacking
- Up to 4 10G ports in basic configuration
- Redundant power supplies, hot-swappable
- Advanced L2 function
- L3 function
- Front to back cooling



Switches of MES3100 series can be used in service provider networks as the district aggregation layer switches or transport switches, as well as in data centres as Top-of-Rack switches (MES3124, MES3124F). They have a substantial margin of performance with versatile interfaces operating at speeds of 10Gbps or 1Gbps.

Support for protocol of rapid convergence of the EAPS allows to get the convergence time of the optical ring of less than 200 ms, which ensures uninterrupted service delivery.

Switches support two power modules with the ability to automatically switch to the redundant module, as well as hot swappable power modules.

The distinctive features of MES switches include advanced L2 features, support for static routing, dynamic routing, availability of up to 4 10Gbps (SFP+) interfaces, stackable up to 8 devices, redundant power supplies, hot-swappable

SPECIFICATIONS

	MES3108F	MES3116F	MES3124	MES3124F
INTERFACES				
10/100/1000Base-T(RJ-45)			24	
100/1000Base-X(SFP)	4	12		20
10/100/1000 Base-T/ 1000Base-X (SFP)	4	4		4
10G Base-R/1000Base-X(SFP+/SFP)	2	2	4	4
Console			RS-232	
PERFORMANCE				
Switch Capacity	56 Gbps	72 Gbps	128 Gbps	
MAC-addresses				16K
Active VLAN IDs				4K
ACL table				2K
Maximum packet size (Jumbo Frame)				10K

TECHNICAL SPECIFICATIONS

PHYSICAL INTERFACES FEATURES

- HOL
- Back pressure
- MDI/MDIX
- Jumbo frames
- IEEE 802.3X

MAC-ADDRESS TABLE FEATURES

- Up to 16K MAC-addresses
- Unblocking per-VLAN learning
- MAC Multicast Support
- MAC-addresses aging
- Static MAC Entries

LAYER L2

- IGMP Snooping
- MLD Snooping
- Multicast profiles support
- IGMP snooping fast leave
- IGMP snooping host-based fast leave
- Broadcast storm control
- Port Mirroring
- Protected ports
- Private VLAN Edge
- Private VLAN (light version)
- STP (Spanning Tree Protocol)
- RSTP (Rapid spanning tree protocol)
- RSTP multiprocessing (up to 32 independent processes)
- MSTP (Multiple STP)
- Ethernet Automatic Protection Switching (EAPS)
- VLAN
- GVRP (GARP VLAN)
- Port-Based VLAN
- 802.1Q
- Super VLAN¹
- Selective Q-in-Q
- LACP
- Static LAG
- Auto Voice VLAN
- IGMP Proxy
- Loopback Detection
- Ethernet OAM
- ULDP (Unidirection link detection protocol)
- Ethernet CFM
- ERPS G.8032v2

LAYER L3 ROUTING PERFORMANCE

- RIP Routes: up to 512
- OSPF Routes (IPv4/IPv6)
 - up to 12k (Ipv4)
 - up to 3k (Ipv6)
- BootP and DHCP(Dynamic Host Configuration Protocol) clients
- Static Routes
- Routing Information Protocol (RIP) v1/v2
- ARP (Address Resolution Protocol), ARP Proxy
- Open Shortest Path First (OSPF) v1/v2
- Virtual Redundant Routing Protocol (VRRP)

SECURITY

- DHCP snooping
- DHCP option 82
- UDP Relay, DHCP Relay
- IP Source address guard
- Dynamic ARP Inspection (Protection)
- Port security
- 802.1x
- SSL v1/v2/v3
- BPDU guard
- PPPoE Intermediate agent

MULTICAST

- 1K multicast groups
- PIM-SM¹

AAA

- WAC
- Management ACL
- Guest VLAN

ACCESS CONTROL LIST (ACLs)

- up to 2048 rules
- L2-L3-L4 ACL (Access Control List)
- Time-Based ACL
- ACL rules based:
 - 802.1p marks
 - VLAN ID
 - MAC-addresses
 - Ethernet type
 - IPv4/v6-addresses
 - DSCP
 - Protocol type
 - TCP/UDP port number
 - IPv6 class
 - IPv6 flow mark
 - User defined mask
- ACL statistics¹

QUALITY OF SERVICES

- 8 Priority Queues per port
- Layer 3 Trusted Mode (DSCP)
- 802.1p Class of Service
- Adjustable Weighted-Round-Robin (WRR) and Strict Queue Scheduling
- CoS
 - 802.1p marks
 - VLAN ID
 - MAC
 - Ethernet type
 - IPv4/v6-addresses
 - DSCP
 - Protocol type
 - TCP/UDP port number
 - IPv6 class
 - IPv6 flow mark
 - User defined mask
 - QoS Policies Aggregation
 - QoS Statistics
 - Traffic shaping (Ingress/Egress, low value 64Kpbs)
 - Time-based QoS

¹Will be supported be next Release

Technical specifications

OAM

- 802.3ah Ethernet Link OAM
- Dying Gasp
- 802.1ag Connectivity Fault Management (CFM)
- 802.3ah Unidirectional LinkDetection (DULD)

MANAGEMENT

- Web
- Multiple configuration file upload/download via TFTP
- RMON
- SNMP
- CLI
- Syslog
- SNTP (Simple Network Time Protocol) Support
- Traceroute
- Privilege level
- Local database
- RADIUS TACACS+ client
- SSH server
- Macro commands support
- Telnet server
- Telnet client
- Zmodem
- System Log
- sFlow
- LLDP
- BootP/DHCP-client
- DHCP Auto Configuration
- DHCP Relay
- DHCP Relay Option 60; 61
- DHCP Relay Option 82
- DHCP server
- Debug commands
- FTP Server

SERVICE FEATURES

- VCT
- SFP/SFP+ transceiver diagnostics
- Dynamic fan control
- Green Ethernet

MONITORING

- Interfaces Statistics
- RMON/SMON
- CPU utilization
- Temperature monitoring
- TCAM utilization

MIB/IETF STANDARDS

- RFC1213 MIB-II
- RFC1493 Bridge MIB
- RFC1907 SNMPv2 MIB
- RFC2571~2576 SNMP MIB
- RFC1271, 2819 RMON MIB
- RFC2021 RMON v2 MIB
- RFC2665 Ether-like MIB
- RFC2668 MAU MIB
- RFC2674 802.1p MIB
- RFC2233, 2863 IF MIB
- RFC2618 RADIUS Authentication Client MIB
- RFC1724 RIP v2 MIB
- RFC1850 OSPF v2 MIB
- RFC2096 IP Forwarding Table MIB (CIDR)
- RFC2787 VRRP MIB
- RFC2932 IPv4 Multicast Routing MIB
- RFC2934 PIM MIB for Ipv4¹
- RFC2620 RADIUS Accounting Client MIB
- RFC2933 IGMP MIB
- RFC783 TFTP
- RFC 791 IP
- RFC 792 ICMP
- RFC 793 TCP
- RFC 826 ARP
- RFC854 Telnet
- RFC951, 1542 BootP
- RFC2068 HTTP
- RFC2138 RADIUS
- RFC2139 RADIUS Accounting
- RFC1492 TACACS
- RFC3176 sFlow
- RFC2598 DiffServ Expedited Forwarding

PHYSICAL AND ENVIRONMENTAL SPECIFICATIONS

- Internal Power Supply Voltage:² 220V AC, 50Hz / 48V DC
- Max Power Consumption: 50W
- Operating Temperature: +10° to 45° C
- Storage Temperature: -40° to +70° C
- Humidity: up to 80%, non-condensing
- 4 fan module
- Dimensions: with internal power supply module 430x44x258 (HxWxD) mm, 19-inch, 1 RU chassis



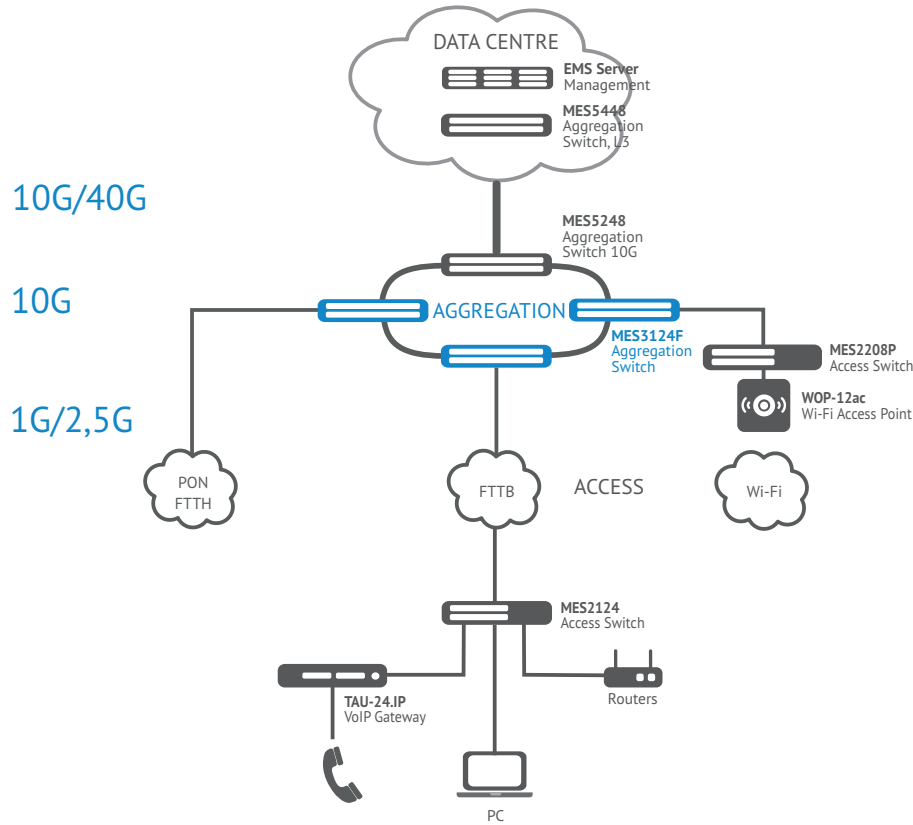

¹Will be supported be next Release

²You can choose this option when ordering

SCHEME OF USING



ORDERING INFORMATION

Name	Description	Picture
MES3108F AC/DC	Ethernet-switch MES3108F, 4 x 1000Base-X(SFP) ports, 4 x combo 10/100/1000Base-T/1000Base-X(SFP) ports, 2 x 10GBase-X(SFP+) ports, L3, 220V AC or 48V DC (160-220/12 or PM75-48/12 supply modules) ¹	
MES3116F AC/DC	Ethernet-switch MES3116F, 12 x 1000Base-X(SFP) ports, 4 x combo 10/100/1000Base-T/1000Base-X(SFP) ports, 2 x 10GBase-X(SFP+) ports, L3, 220V AC or 48V DC (160-220/12 or PM75-48/12 supply modules) ¹	
MES3124F AC/DC	Ethernet-switch MES3124F, 20 x 1000Base-X(SFP) ports, 4 x combo 10/100/1000Base-T/1000Base-X(SFP) ports, 4 x 10GBase-X(SFP+) ports, L3, 220V AC or 48V DC (160-220/12 or PM75-48/12 supply modules) ¹	
MES3124 AC/DC	Ethernet-switch MES3124, 24 x 10/100/1000Base-T ports, 4 x 10GBase-X(SFP+) ports, L3, 220V AC or 48V DC (160-220/12 or PM75-48/12 supply modules) ¹	

Software

EMS-MES-3100

Eltex.EMS management system option EMS-OLT for management of network equipment Eltex. per 1 MES

¹You can choose this option when ordering

About Eltex

For more than twenty years major Russian company Eltex Enterprise, Ltd been designing and manufacturing a wide range of telecommunications and networking equipment: GPON devices, Ethernet-switches, Service Routers, Wireless, VoIP-gateways, Softswitch & IMS, Set-top Boxes and much more.

Contact Us



+7 (383) 274 10 01
+7 (383) 274 48 49



eltex@eltex.nsk.ru



www.eltex.nsk.ru